

System One®

Stand-By Power Supply

**For Residential,
Commercial,
Industrial, and
Municipal
Applications.**

Computers



Servers



Telephones



Automatic Dialers



Emergency
Lights



Exit Signs



Furnaces



Boats



Motor Homes



- Powers your existing equipment in an outage.
- Easy installation, no modifications or wiring changes.
- Works with any 115V appliance up to 12 amps or 1400 watts.
- Fully automatic charging system.
- Made in U.S.A.
- Microprocessor based system design for consistent and reliable operation.



Patent #1,881,196

BY THE MAKERS OF
SUMPRO



System One®

Stand-By Power Supply

Specifications

- V/A Watts - 1800/1440
- Lighting and Surge Protection - Passes ANSI/IEEE C62.41 Categories A and B
- Spike Attenuation - 1500 to 1
- Noise (RF) Isolation - 110 db Common Mode
- Input - 96-132VAC (Adjustable)
- Regulation (Inverter Operation) - +/-10%
- Output Wave form - Stepped Sine Weighted 25% Max. (Distortion) THD
- Output Protection (Inverter Operation) - over current
- Efficiency - 98% On Line
- Audible Noise - 52 db
- Operating Environment - 0° to 40° C (32° to 104°F), 0 to 95% Relative Humidity (Non-Condensing)
- Altitude - To 1000 Meters
- Transfer Time - 1-1/2 Cycles/25MS Max.
- Battery Recharge Time - 4 Hrs.
- Common Mode Noise Filter - EMI and RFI
- High Peak RMS Ration Crest Factor 5:1
- Long Battery Life - 3 hrs. on Computer
- MOV's for Surge Protection - 6500 Amp peak

Total Average Running Time

Power Consumption	Watts Amps	300 2.6	600 5.2	900 7.8	1200 10.4	1400 12.0
Running Time (Continuous Power Draw)		180 Min	90 Min	75 Min	60 Min	40 Min

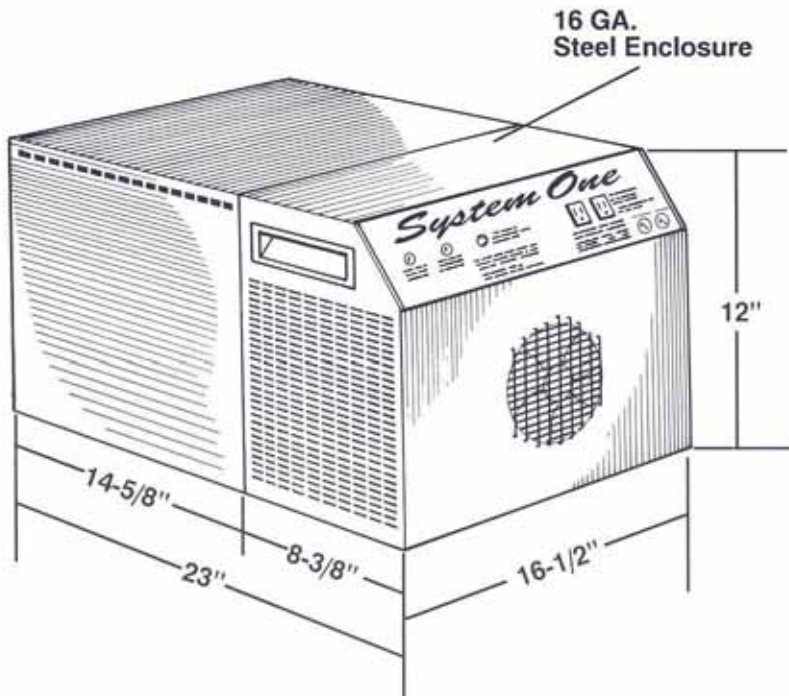

Model #15

Input: 60 Hz, 120 VAC, 12 AMP
 Output: 120 VAC, 15 AMP, at
 .80 service factor Max HP: 1/2
 Full One Year Guarantee
 Shipping Weight:
 Powerhead - 70 lbs.,
 Battery Enclosure - 25 lbs.,
 Batteries - 54 lbs. each
 Total 4 pieces

System One can be shipped anywhere.

Manufacturers, Distributors and Innovators of Quality Equipment!



37 Forestwood Drive, Romeoville, IL 60446

Telephone: (815) 886-9200

www.metropolitanind.com