





ION™

DIGITAL LEVEL CONTROL

patent pending



-  First of a kind solid-state sensing technology with no moving parts
-  Multipoint sealing mechanism that supersedes single surface seals
-  Inverter rated for use with most battery back-up systems
-  Space age design with no contact points



The Pumping World's One Stop Shop!™



DIGITAL LEVEL CONTROL SET TO REPLACE MECHANICAL FLOAT SWITCHES

Metropolitan Industries is pleased to announce the launch of the world's first digital level controller for use with residential sump and sewage pumps eliminating moving parts associated with 98% of mechanical switch failures.

Under development for several years, the patent-pending Ion Digital Level Controller will replace unreliable mechanical float switches using solid-state sensing computer technology eliminating contact points and moving parts making it superior to conventional switch technology.

The problem was never the pump because they are generally built to last. The problem has always been the switch responsible for the critical task of turning the pump on and off. Mechanical switches use moving parts and wear and tear in a sump pit environment will always break those components down over time. With the Ion Digital Level Controller, smart computer technology replaces moving parts for the ultimate in protection.

First of a kind solid-state sensing technology

Contact protection specifically designed to handle high inrush current pump loads

Space age solid state design with no contact points

Differential heights of 6 inch for standard sump applications and 10 inch for sewage applications

Leak resistant and extremely durable proprietary enclosure

Multiple stainless steel screws supply optimized pressure ensuring superior sealing properties and durability



SPECIFICATIONS

- ⚡ Rated for both effluent and sewage use with pumps using a piggy back plug system
- ⚡ For use with all 120 vac pumps up to 15 amps
- ⚡ Inverter rated for use with most back up systems
- ⚡ Auto power reset, "NO TOUCH" design
- ⚡ No maintenance or cleaning required
- ⚡ Factory calibrated

DIMENSIONS

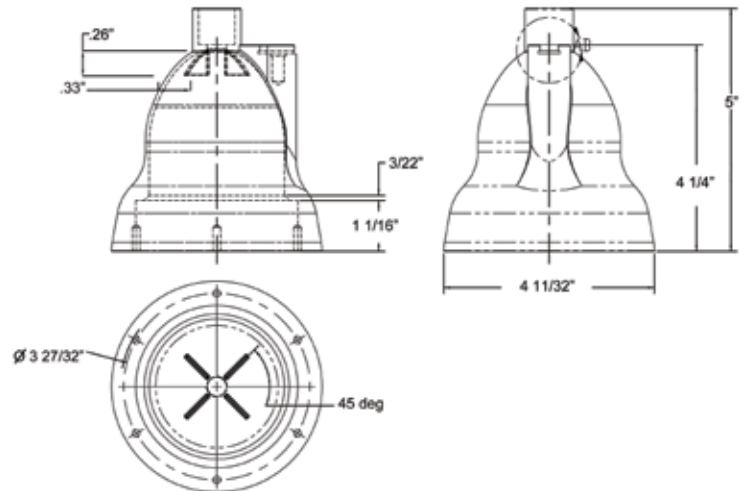

THE SWITCH IS ON AT WWW.IONNATION.US



37 Forestwood Drive, Romeoville, IL 60446-1343
Telephone: (877) 330-5385