

Metro-Prime - 30 MPC

Self-Priming Sewage & Trash Pumps,
Close Coupled

OPERATION & MAINTENANCE MANUAL

Dated: 7/11/03

Supersedes: None

Document No.: MPC30-OM-01

Page 1 of 5

GENERAL INFORMATION

RECEIVING PUMP

Pump should be checked on arrival for possible damage in shipping. Any damage should be reported immediately to delivering carrier. Claims for damage must be made at the receiving end through the delivering carrier. Claims for shipping damage cannot be processed at the factory.

PUMPS NOT OPERATING OR IN STORAGE

If pump is not to be put into service immediately, it must be properly stored to prevent damage. Store unit in a dry warm location. Never store unit in the open even if it is protected with plastic or other covering as bearing and motor will draw moisture which may result in failure after being put in operation.

Pumps with carbon ceramic seals must have impellers manually rotated (6 revolutions) after setting non-operational for 3 months or longer and prior to electrical start-up.

Pumps with tungsten carbide seals must have impellers manually rotated (6 revolutions) after setting non-operational for 3 weeks or longer and prior to electrical start-up.

PUMP TYPE

Pumps are of the built-on motor type with motor shaft extended to drive pump impeller. Sectional drawing for the MPC pump is on Page 5.

MOTORS

The motors used with the MPC pumps are of the built-on type with round frame and "C" flange construction with extended stainless steel shaft to drive the pump impeller. The impeller is screwed onto the motor shaft with a right hand thread. Motors supplied are open drip-proof.

SUMP LEVEL CONTROL

Sump level can be controlled by float switch.

FLOAT CONTROL

For a duplex system, a float operated mechanical alternator is used to alternate pumps on each successive cycle and to turn on second pump if one pump can not handle the inflow. For a simplex system a float operated switch is used to start and stop the pump.

3900 CONTROLS

Three 3900 level controls are required for a duplex system. Lower control stops pump, first upper control starts pumps and alternates pumps on each successive cycle. Second upper control starts second pump if one pump cannot handle the inflow. A fourth control is used to operate an alarm system.

ALARM CONTROLS

High level alarms can be supplied for compression type, float operated type, or to operate with 3900 control.

ELECTRICAL STARTING EQUIPMENT

If starting equipment is not furnished with pump, certain precautions must be observed in selecting starter.

TYPE OF STARTER

Magnetic starters with 3 leg overload protection are recommended to prevent motor burn out that can occur from single phasing or transformer faults on three phase systems. For single phase motors a standard starter with 2 leg protection is recommended.

ELECTRICAL

1. For open drip-proof motors the heater trip amp rating should not be more than 1.25 times the full load amps of motor. Table 1 gives full load amps rating of open drip-proof General Electric single phase and 3 phase motors.
2. Always use fused disconnect switch or circuit breaker ahead of magnetic starter for short circuit protection.

Table 1

Motor Horsepower	3 Phase Full Load Amps 230 V		Single Phase Full Load Amps 230V	
	1150 RPM	1750 RPM	1150 RPM	1750 RPM
1	3.8	-	8.4	-
1.5	5.7	-	12.5	-
2	6.6	6.2	15.2	12.4
3	10.0	6.6	17.2	17.0
5	16.2	14.2	-	29.5
7.5	-	21.0	-	35.6
10	-	26.8	-	-
15	-	42.0	-	-

Metro-Prime - 30 MPC

Self-Priming Sewage & Trash Pumps,
Close Coupled

OPERATION & MAINTENANCE MANUAL

Dated: 7/11/03

Supersedes: None

Document No.: MPC30-OM-01

Page 2 of 5

When duplex pumps are used and are operated from a single disconnect switch be sure fused switch is large enough to stand the starting current of both pumps coming on at once as can occur after a power failure.

This is important as a blown fuse can make both pumps and an alarm system inoperative resulting in flooding or other damage.

Table 2 gives size of fused switch, wire size and conduit size required from pump control to power service pole.

IMPORTANT!

Use a carried ground wire #8 stranded bare or insulated in all conduit. Connect ground wire to motors, control box and other controls. Ground wire must be connected to a driven ground stake or to a buried water pipe. If a ground stake is used it must be driven at least 8 feet into the ground.

CODES

All local wiring codes must be observed and any exceptions to data given must be followed in accordance with the local code. Consult the local inspector before installation to avoid costly delays that can occur due to rejection after job is finished.

INSTALLATION INSTRUCTIONS

TYPE OF INSTALLATION

The MPC pumps are generally mounted directly on the sump cover. Pumps can be mounted off the cover on a concrete base if desired. When pumps are mounted off the cover, suction pipes must be supported to remove weight from the pump casing.

Table 2. For duplex pumps

Motor H.P.	Fusible Entrance Switch Size 1 Phase 230V	Wire Size 1 Phase 230V	Conduit Size 1 Phase 230V	Fusible Entrance Switch Size 3 Phase 230V	Wire Size 3 Phase 230V	Conduit Size 3 Phase 230V
1	30	10	1"	30	14	1
1.5	30	10	1"	30	12	1
2	60	8	1-1/4"	30	12	1
3	100	6	1-1/2"	30	10	1
5	100	3	1-1/2"	60	8	1-1/4
7.5	-	-	-	100	6	1-1/2
10	-	-	-	100	4	1-1/2
15	-	-	-	200	1	2
20	-	-	-	200	2/0	2-1/2

PIPING

When installing piping be sure all joints are tight especially on the suction lines. Attach suction elbow to suction pipe and lower into place through cover plate. Bolt suction flange to case flange, be sure gasket is in place between flanges.

VERTICAL SUCTION LIFT

Maximum vertical lift for dry prime depends on pump model, motor speed and pump total head required. Check pump performance curve for maximum priming and pumping suction lift. The fact that a pump will dry prime to a certain vertical lift does not mean the pump can operate at this lift without cavitating. Operating suction lift is based on total suction lift which includes vertical lift plus friction and entrance losses in the suction piping.

ELECTRICAL CONNECTIONS

Make all connections from motor to control panel to comply with local codes.

CAUTION!

Be sure a ground wire is connected to the motor frame and is carried to a satisfactory ground. If controls are supplied, complete wiring diagrams are included with the panel.

STARTING SYSTEM

THREE PHASE

If motor is 3 phase, check rotation before starting motor. Remove end shield of motor so that rotation of fan can be observed. Turn motor on and off quickly to check rotation. Rotation should be clockwise when standing behind the motor. To change rotation, interchange any two line leads to the motor. Do not interchange incoming power lines. Be sure motor connections correspond to the voltage supply.

Metro-Prime - 30 MPC

Self-Priming Sewage & Trash Pumps,
Close Coupled

OPERATION & MAINTENANCE MANUAL

Dated: 7/11/03

Supersedes: None

Document No.: MPC30-OM-01

Page 3 of 5

PRIMING PUMP

Remove priming cap on suction inlet box and fill case with water. Have air vent valves open with filling case. Replace priming cap, be sure gasket is in place.

Turn H-O-A switch to hand position to start motor. Allow sufficient time for priming. Pump requires longer to prime at 1150 RPM than at 1750 RPM, and longer for higher lifts. Usual priming time is 3 to 5 minutes.

After pumps are primed and operating, turn selector switch for both pumps to auto position and check automatic operation. Allow level in sump to rise until one pump starts.

For float operation, adjust stops on rod so that pump comes on when level rises about 20 inches. With 3900 controls the turn on level switch should be about 20 inches above turn off level switch. Allow pump to cycle causing alternation of pumps on each successive cycle.

Turn off power and allow sump level to rise to override position. Turn power on and both pumps should start and operate together until level drops to the stop position. The override position is the same with either the flat or 3900 controls, that is, both pumps operate together once started until level drops to turn off point.

VENT VALVE

If manual air vent valves are used, they should be left open so that water will circulate to the sump when pump is operating. Check in sump to be sure water is circulating. Line may become plugged with solids, so remove line and clean out if necessary.

IMPORTANT

A self-priming pump cannot compress air, so air must be vented off at atmospheric pressure before pump can start and pump under pressure.

LUBRICATION

The only bearings for pump and motor are in the motor. Bearings are properly greased when leaving factory and should not require greasing for two years.

Excessive or too frequent lubrication can damage bearings and motor windings. Use grease fitting in top plug opening and remove lower plug so that old grease can be forced out. Lubricate when motor is warm and when standing idle. Replace plugs after lubricating bearings. Use only GE D6A2C5 grease in the bearing. The grease can be obtained from a GE supply house.

MAINTENANCE

REPLACING IMPELLER AND VOLUTE LIP PLATE

Drain pump case and remove bracket and motor as unit.

Back off screws are provided in the bracket to loosen from pump case. Remove locking screw and washer from end shaft. Use large screw driver or flat bar in slot end of shaft and bump on end of impeller vane counterclockwise with hardwood block. If impeller does not loosen by this method it may be necessary to remove motor end cover and hold fan with large screw driver while bumping the impeller loose with the wood block. Use care not to damage the fan.

Next remove stainless screws from volute plate. The MPC pumps have screws that hold vane plate from the inside. Replace with new parts, also replace suction wear plate if worn. Be sure seal spring is in place before replacing impeller. It may be necessary to add stainless shims behind impeller hub to properly space impeller.

Impeller face should be about 10 to 15 thousandths inside volute lip face. If full diameter impeller is used where there is no vane lip, it will be necessary to add shims. Then assemble the pump to check for clearance by using a machinist square.

REPLACING SHAFT SEAL

The MPC face seal has a ceramic stationary face and a carbon rotating face. The rotation part of the seal is mounted on a stainless replaceable sleeve that is held in place by the impeller. To replace the seal remove impeller and lip plate as described above. Now remove sleeve from motor shaft. It may be necessary to loosen bolts in the motor bracket and bump with plastic hammer to loosen seal and sleeve. If sleeve is not damaged it may be reused.

Clean all parts thoroughly before installing new seal. Replace stationary ceramic seal in motor bracket then push rubber section with carbon seal face onto sleeve. Use O-Ring on shoulder of shaft to prevent leakage under sleeve.

Now replace lip plate and fasten with screws. Put seal spring in place and screw impeller onto shaft. Bump impeller against sleeve using hardwood block on impeller vane. Now replace lock washer and screw. Use LOCKTITE on threads of locking screw. Reassemble unit in pump casing.

CAUTION!

Never reuse old seal parts. Always replace with complete new seal.

Seal faces should be lubricated with a non-detergent motor oil.

COMPLETE ROTATING UNIT SIMPLIFIES MAINTENANCE

The complete rotating unit includes motor, bracket, seal, volute lip plate and impeller. All can be easily removed from the pump as an integral unit without disturbing the

Metro-Prime - 30 MPC

Self-Priming Sewage & Trash Pumps,
Close Coupled

OPERATION & MAINTENANCE MANUAL

Dated: 7/11/03

Supersedes: None

Document No.: MPC30-OM-01

Page 4 of 5

pump case or system piping. Simplifies the replacement of worn impellers, volute lip plates and shaft seals.

QUICK CLEAN OUT

If the pump should clog due to the intrusion of rags or other stringy material, pump may be unclogged in minutes by loosening four wing bolts and removing suction elbow. This completely exposes impeller and pump case interior. No need to disconnect other piping.

TROUBLE CHECK LIST

⚠ WARNING

Read all instructions before starting any operation on pumps. Always disconnect the pump and controls from its power source before handling. Do not smoke or use sparkable electrical devices or flame in a septic (gaseous) or possible septic sump.

Pump will not prime.

1. Pump case has not been filled with water.
2. Motor rotation may be wrong. Rotation is clockwise when standing behind the motor.
3. Vertical suction lift may be too high. Fry prime heights are given on the curve sheets of the MPC pumps.
4. Suction line may have an air leak. Use vacuum gage at pump inlet to check for leak. Start pump and watch gage. As pump primes gage hand goes up, stop pump and see if hand will hold position. If hand falls back, a suction leak is indicated. Recheck all suction threads and gaskets.
5. Check for obstruction in impeller. Remove inlet elbow to check.
6. Air bleed line may be plugged. Water and air should vent into sump.

Pump occasionally loses prime and pump case gets hot.

1. Air bleed line may be plugged.
2. Inlet check valve may be worn or broken. Inspect through suction opening when elbow is removed. Replace of worn or broken.
3. The priming port may be plugged. Priming port extends from upper case into volute chamber.
4. Impeller face clearance and lip clearance may be too great due to wear. Impeller and lip plate should be replaced if obvious wear is present.

Pump makes a cracking noise when operating.

1. Suction line may be partially blocked. Use vacuum gage at pump inlet. If high reading shows above 25 ft., check for pluggage in suction pipe.
2. Pump may be delivering too much capacity due to reduced or miscalculated head, causing pump to cavitate. Reducing impeller diameter will help this condition. If necessary to reduce impeller diameter both impeller and lip plate must be replaced. Use vacuum gage to determine maximum suction lift.
3. Pump may be operating too near to shut off capacity due to head being higher than calculated. At reduced capacity under 100 GPM, all self-priming pumps tend to be noisy. Pumps should not be selected to operate at this range. Performance curve on MPC pumps show operating range enclosed by heavy line. For quiet operation pump must be operated within this range.

Pump does not deliver rated capacity.

1. Total head may be higher than estimated. Total head is taken when pump is operating. This is vacuum gage reading in feet plus discharge gage reading in feet.
2. Pump impeller may be worn. Replace impeller and lip plate if obvious wear shows when suction elbow is removed.
3. Suction lift may be too high. Check curve for maximum total suction lift. If suction lift is too high pump can not deliver maximum capacity and cavitation will result.
4. Check for partially clogged impeller.

Motor starter overloads trip after pump has operated for short period.

1. Rags or trash may be caught in impeller causing extra load on motor. Remove suction elbow and clean. Impeller should turn freely by hand.

CAUTION!

Always turn off power before working on impeller or pumps.

2. Overload heater may be too small. Check amp rating of heater with full load amps of motor. See heater table for proper size.
3. Pump may be pumping oil or other liquid with higher viscosity than water resulting in increased motor load.
4. If motor hums and does not start, check for blown fuse at main pump switch, or impeller jammed so that shaft cannot turn.

Metro-Prime - 30 MPC

Self-Priming Sewage & Trash Pumps,
Close Coupled

OPERATION & MAINTENANCE MANUAL

Dated: 7/11/03

Supersedes: None

Document No.: MPC30-OM-01

Page 5 of 5

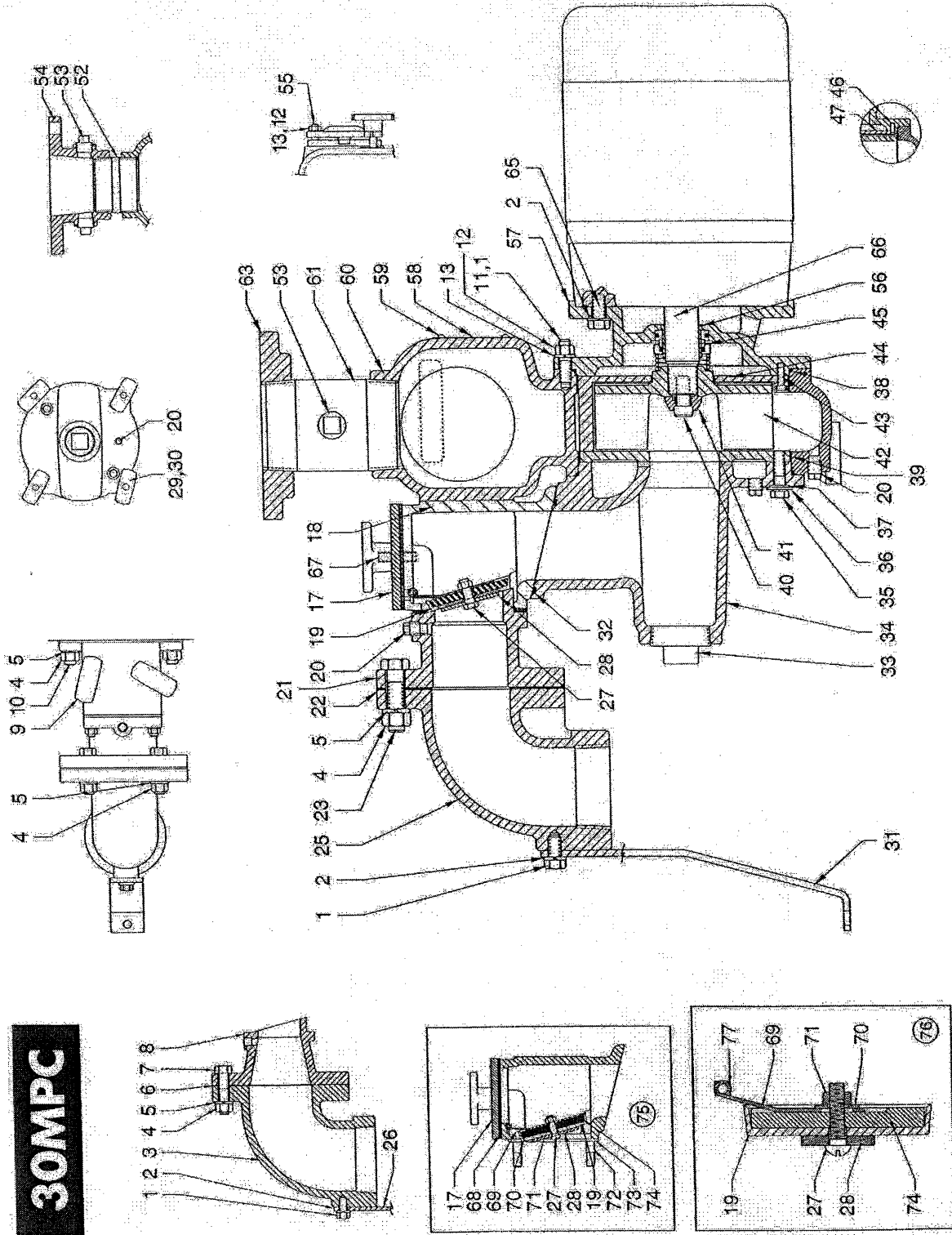

30MPC

Metro-Prime - 30 MPC

Self-Priming Sewage & Trash Pumps,
Close Coupled

OPERATION & MAINTENANCE MANUAL

Dated: 7/11/03

Supersedes: None

Document No.: MPC30-OM-01

Page 6 of 5

30MPC PARTS LIST

Ref. No.	Part No.	Part Description	Qty.	Ref. No.	Part No.	Part Description	Qty.	Ref. No.	Part No.	Part Description	Qty.
1	00249-003-1	Bolt	3	32	00241-004-1	O-Ring	SC	51	01070-000-2	Clamp Arm	1
2	00177-010-1	Lockwasher	1	33	02589-001-1	Pipe Plug		52	07287-055-1	3" Close Pipe Nipple	1
3	03613-000-2	Suction Elbow 4"	1	34	01059-002-2	Suction Elbow		53	00120-001-1	Pipe Plug	2
4	01124-003-1	Nut (3" x 3")	6	35	00238-008-1	Bolt		54	02050-000-2	Discharge Flange 3" x 4"	1
5	01124-003-1	Nut (4" x 4")	10	36	00150-048-1	Washer		55	01079-003-1	Stud	2
6	00177-011-1	Lockwasher	6	37	01037-002-1	Stat-o-seal	SC	56	03296-001-1	Sleeve	SC
7	02407-002-1	Gasket #1	1	38	00150-023-1	O-Ring	SC	57	03257-000-2	Intermediate Bracket	1
8	00570-012-1	Bolt	8	39	01060-000-2	Wear Plate		58	13422-029-1	Nameplate	1
9	02049-000-2	Suction Flange (3" x 4")	1	40	00569-010-1	Impeller Bolt		59	04580-001-1	Drive Screw	4
10	00905-002-2	Clamp Handle	2	41	01039-000-5	Impeller Washer		60	01057-000-2	Yolute Case	1
11	01030-008-1	Stud	2	42	01061-000-2	Impellers, 8 3/8" Dia		61	06462-000-5	Pipe Nipple 3" x 5"	1
12	01079-002-1	Stud	6	43	01061-008-2	Impellers, 7 1/2" Dia		63	01595-001-1	Discharge Flange	1
13	01085-001-1	Nut	11	44	01061-012-2	Impellers, 7 1/2" Dia		65	00239-006-1	Bolt	4
14	00177-009-1	Lockwasher	11	45	01172-003-2	Impeller, 7" Dia		66	00079-008-1	O-Ring	SC
15	12009-000-3	Priming Cover	1	46	01179-004-2	Impeller, 6 1/2" Dia		67	01027-002-1	Stud	2
16	11999-000-2	Suction Box	1	47	00317-003-1	Cap screw		68*	12015-000-1	Top Gasket	SC
17*	12014-001-1	Flap Valve	1	48	02004-000-2	Flat Plate, 8 3/8" Dia		69**	12011-000-1	Flange	1
18	00119-001-1	Pipe Plug	3	49	01211-002-2	Lip Plate, 7 1/2" Dia		70**	00156-047-1	Flat Washer	1
19**	01342-000-2	Suction Flange 3"	1	50	01211-005-2	Lip Plate, 7 1/2" Dia		71**	00114-002-1	Nut	4
20	02407-001-1	Gasket #2	4	51	01320-001-2	Lip Plate, 6 1/2" Dia		72*	01079-009-1	Stud	1
21	00570-010-1	Bolt	1	52	00920-001-1	Seal (Ceramic) Std.	S	73*	12013-000-1	Front Gasket	SC
22	03258-000-2	Suction Elbow 3"	1	53	00920-004-1	Seal (Carbide) Opt.	C	74**	01075-001-2	Weight	1
23	00570-010-1	Bolt	4	54	00150-007-1	Flat Head Screw		75	51728-000-5	Flap Valve Box Assembly	1
24	00570-010-1	Bolt	1	55	02004-000-2	Flat Plate for 8 3/8" Dia Impeller Only		76	12011-010-5	Flap Valve Assembly	2
25	03258-000-2	Suction Elbow 3"	1	56	01068-000-2	Inspection Cover		77‡	13484-000-1	Sleeve	1
26	03260-001-3	Support Bracket	1	57	00241-007-1	O-Ring	SC	78	51700-009-7	Seal Kit	1
27**	13123-002-1	Bolt	1	58	00905-001-1	Clamp Handle		79	51700-339-7	Carbide Seal Kit	1
28**	00156-059-1	Washer	4	59	00905-001-1	Clamp Handle		80**		Impeller Kit	1
29	00905-000-2	Clamp Handle	4	60	00905-001-1	Clamp Handle					
30	01024-001-1	Stud	4	61	00905-001-1	Clamp Handle					
31	03260-001-3	Support Bracket 3"	1	62	00905-001-1	Clamp Handle					

Notes: *Piece #75, Flap Valve Box Assembly, consists of pieces 17, 19, 21, 23, 68, 69, 70, 71, 72, 73, and 74.

‡Piece #76, Flap Valve Assembly, consists of pieces 19, 21, 23, 69, 70, 71, 74, and 77.

S — Parts in Seal Kit. C — Parts in Carbide Seal Kit. † — Parts in Impeller Kit. **Consult Factory.

ORDERING REPLACEMENT PARTS

Product improvements are made from time to time. The latest part design will be furnished as long as it is interchangeable with the old part. When ordering replacement parts, always furnish the following information: (1) pump serial number, (2) pump model and size, (3) part description, (4) part number, (5) impeller diameter (if ordering impeller), (6) quantity required, and (7) shipping instructions.